

A Zeugma Systems White Paper by Siegfried Luft

Embedding Applications in Carrier-Class Network Elements

Service providers have always operated in a world that is characterized by five-nines reliability and a very high degree of determinism in network behavior. This is, of course, a function of the criticality of the services they deliver. But service providers pay for this carrier-grade reliability with long upgrade cycles. Embedded systems software in core network elements is updated infrequently and at great risk. Want a new service? Wait a year. Maybe two.

Contrast this with the world of web applications. Entirely a software world, this fast-paced environment enables providers to dream up, prototype, and deploy new services in a matter of weeks. But providers of web services pay for this speed and dexterity with reduced reliability. Forget five nines. Five sixes might be a job well done. Quality is job 2.0.

The challenge for broadband service providers (BSPs) is that the world is changing too quickly to wait around for 18-24 months while a new service is being developed. There's also the question of uncertainty: we don't often know which service will be a hit and which will be a dud. Waiting 18 to 24 months to discover that a service failed and garner sufficient market traction to justify the capital investment is unacceptable. As one service provider told me, "We need to be able to fail fast." While this might sound counterintuitive it's actually true—the quicker you fail the quicker you'll find a service that's a winner.

BSPs understand this dilemma, but they also understand that the move to quicker, more nimble service deployment can't come at the expense of the carrier-grade reliability that has long been a hallmark of their networks.

Figure 1
Conventional Server-based Application Intelligence

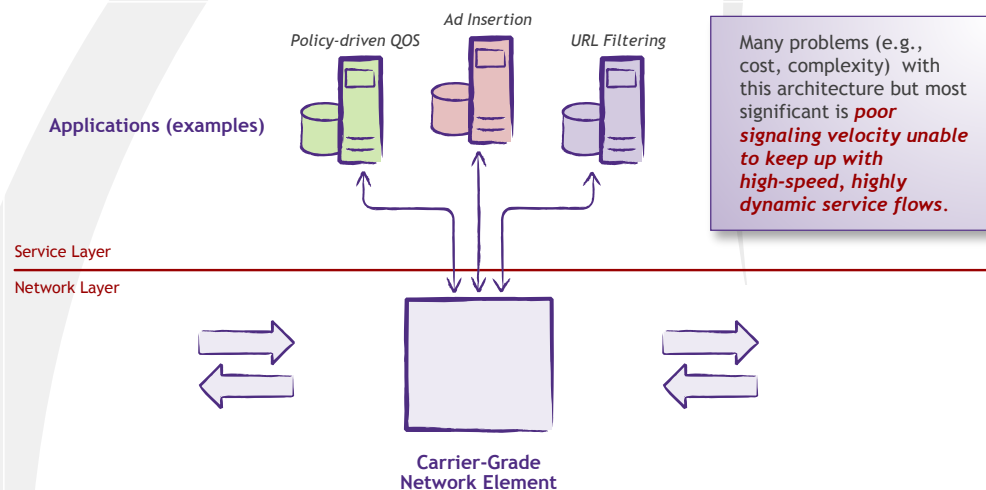

A potential path forward has been to use server-based software—i.e., a combination of probes and policy and management systems—to observe and control what is going on in the network. This approach has been broadly employed for years and is fundamental to IMS. The approach does have merit. Software systems can be updated often and with less risk to

the underlying network infrastructure so service providers can, in theory, quickly test, develop, and deploy new services.

However, there is a major drawback to this type of architecture, and it is likely to become more pronounced over time. In general, we are dealing with a location in the network (frequently called the broadband edge) that is likely to support hundreds of thousands of subscribers and millions of session flows. With the dramatic increase in over-the-top (OTT) video traffic, many of these session flows are carrying enormous amounts of information, in some cases long-form, high-definition video.

Some session flows, VOIP and gaming in particular, change state with great frequency. Expecting external systems to observe network behavior, develop policy-based rules, and enforce those rules over a myriad of devices quickly enough to matter may not be technically possible. It does little good, for example, if it takes minutes to determine that a VOIP call should receive enhanced QOS; the call is likely to be terminated by the time the policy is enforced.

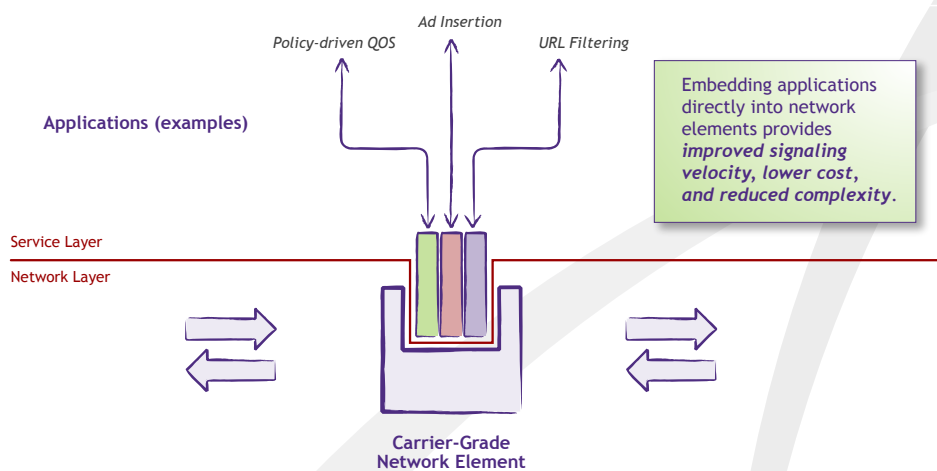

Figure 2

Embedded Software Applications Reduce Cost, Enhance Functionality

There are many other examples where the latency involved in the “identify session / determine policy / enforce policy” cycle is too high to be of value.

The solution is increasingly to embed service logic—the software applications—directly within the network element. There are many ways to do this (and several equipment suppliers have begun moving in this direction), but at a minimum the architecture should allow for the following:

- A protected application environment. Embedding applications in a carrier-grade network element requires that we take steps to protect the network element from misbehaving applications.
- Application program interfaces (APIs). Since the primary objective is to place applications near the actual data flows, the applications require APIs so they can safely access the underlying platform (hardware acceleration layer), to both observe and control flows in real time.



- Non-blocking performance. Obviously, with the large number of high-speed data flows traversing these systems, it does little good if the applications absorb too many flows and destroy the characteristics of the network element. Steps must be taken to ensure that applications inspecting traffic are not permitted to negatively impact the throughput of the system or introduce thrashing of application environment. In doing so, the foundational network layer characteristics are safe, even with the introduction of potentially disruptive applications.

While many equipment suppliers have begun taking steps in this direction, a new class of edge network element specifically performs this function. Many analysts are referring to these elements as service delivery routers (SDRs). SDRs perform edge routing, subscriber management, and broadband aggregation, but also include compute capabilities (implementations will vary) so that applications can be written and run directly in the SDR.

Siegfried Luft is the founder and CTO of Zeugma Systems and has 20 years of experience in the telecommunications industry. Prior to Zeugma Systems, he was a co-founder of Siara Systems, which merged with Redback Networks. Siegfried has a number of pending patents related to optical protection mechanisms, highly scalable distributed systems and tiered service routing.

www.zeugmasystems.com
Zeugma Systems, 13571 Commerce Parkway, Richmond, BC, Canada

Copyright © 2008 Zeugma Systems. All rights reserved. This document is protected from unauthorized copying and use by national copyright laws and international conventions. All information in this document is subject to change without notice. Zeugma Systems and the Zeugma Systems logo are trademarks of Zeugma Systems. All other trademarks are the property of their respective owners. Zeugma Systems reserves the right to change specifications or to discontinue products at any time.